

HIGHLIGHTS OF PRESCRIBING INFORMATION

These highlights do not include all the information needed to use ARTISS safely and effectively. See full prescribing information for ARTISS

ARTISS [Fibrin Sealant (Human)]

For Topical Use Only

Frozen solution and lyophilized powder for solution for topical application

Initial U.S. Approval: 2008

RECENT MAJOR CHANGES

INDICATIONS AND USAGE

ARTISS is indicated to adhere autologous skin grafts to surgically prepared wound beds resulting from burns in adult and pediatric populations (1)

ARTISS is not indicated for hemostasis (1)

DOSAGE AND ADMINISTRATION

For Topical Use Only. Do Not Inject (2). Apply on surface of prepared wound beds only (2.3)

ARTISS Kit (Freeze-Dried) requires reconstitution prior to use (2.1)

ARTISS Pre-filled Syringe (Frozen) requires thawing prior to use (2.2)

Apply as a thin layer using the Easyspray and Spray Set (2.3, 5.3)

Dosage: 2 mL will cover approximately 100 cm² surface area (2)

Store ARTISS Kit (Freeze-Dried) at 2-25°C. Avoid Freezing. Use within 4 hours of reconstitution (16)

Store ARTISS Pre-filled Syringe (Frozen) at ≤ -20°C. Unopened pouches, thawed at room temperature, may be stored for up to 7 days at 15-25°C. The product must be used within 12 hours after warming to 33-37°C or removal from original pouches. Do not refrigerate or re-freeze (16)

Vials and pre-filled syringes are for single use only. Discard unused contents (2.3)

DOSAGE FORMS AND STRENGTHS

ARTISS Kit (Freeze-Dried) is supplied as 2 mL, 4 mL and 10 mL (total volume) pack sizes with and without the DUPLOJECT system (3.1)

ARTISS Pre-filled Syringe (Frozen) is supplied as 2 mL, 4 mL and 10 mL (total volume) pack sizes with the DUO set (3.1)

CONTRAINDICATIONS

- Do not inject directly into the circulatory system (4.1)
- Do not use in individuals with a known hypersensitivity to aprotinin (4.2, 5.1, 6.1)

WARNINGS AND PRECAUTIONS

- This product is made from pooled human plasma which may, theoretically, contain infectious agents (5.2)
- Apply only as thin layer (2.3, 5.3)
- Use caution when applying with pressurized gas (5.3)
- Exposure to solutions containing alcohol, iodine or heavy metals may cause ARTISS to be denatured (5.3)

ADVERSE REACTIONS

Adverse reactions occurring in greater than 1% of patients treated with ARTISS were skin graft failure and pruritus (6.1, 6.2)

To report SUSPECTED ADVERSE REACTIONS, contact Baxter Healthcare Corporation at 1-866-888-2472 or FDA at 1-800-FDA-1088 or www.fda.gov/medwatch.

See 17 for PATIENT COUNSELING INFORMATION

Revised: 03/2008

FULL PRESCRIBING INFORMATION: INDEX *

1 INDICATIONS AND USAGE

2 DOSAGE AND ADMINISTRATION

- 2.1 Preparation of ARTISS Kit (Freeze-Dried)
- 2.2 Preparation of ARTISS Pre-filled Syringe (Frozen)
- 2.3 Method of Application

3 DOSAGE FORMS AND STRENGTHS

- 3.1 Presentations and Pack Sizes
- 3.2 Package Contents

4 CONTRAINDICATIONS

- 4.1 Intravascular Application
- 4.2 Aprotinin Hypersensitivity

5 WARNINGS/PRECAUTIONS

- 5.1 Hypersensitivity/Allergic/Anaphylactic Reactions
- 5.2 Infection Risk from Human Plasma
- 5.3 Application Precautions

6 ADVERSE REACTIONS

- 6.1 Overall Adverse Reactions
- 6.2 Clinical Trials Experience
- 6.3 Post Marketing

7 DRUG INTERACTIONS

8 USE IN SPECIFIC POPULATIONS

- 8.1 Pregnancy
- 8.3 Lactating Women
- 8.4 Pediatric Use
- 8.5 Geriatric Use

11 DESCRIPTION

12 CLINICAL PHARMACOLOGY

- 12.1 Mechanism of Action
- 12.2 Pharmacodynamics
- 12.3 Pharmacokinetics
- 12.4 Other Clinical Pharmacology Information

13 NONCLINICAL TOXICOLOGY

- 13.1 Carcinogenesis, Mutagenesis and Impairment of Fertility

14 CLINICAL STUDIES

16 HOW SUPPLIED/STORAGE AND HANDLING

17 PATIENT COUNSELING INFORMATION

* Sections or subsections omitted from the full prescribing information are not listed.

ARTISS [Fibrin Sealant (Human)]

1 INDICATIONS AND USAGE

ARTISS is indicated to adhere autologous skin grafts to surgically prepared wound beds resulting from burns in adult and pediatric populations.

ARTISS is not indicated for hemostasis.

2 DOSAGE AND ADMINISTRATION

FOR TOPICAL USE ONLY – DO NOT INJECT.

The required dose of ARTISS depends on the size of the surface to be covered. The approximate surface areas covered by each package size of ARTISS are:

Table 1.

| Approximate area requiring skin graft fixation | Required package size of ARTISS |
|--|---------------------------------|
| 100 cm ² | 2 mL |
| 200 cm ² | 4 mL |
| 500 cm ² | 10 mL |

2.1 Preparation of ARTISS Kit (Freeze-Dried)

During preparation of ARTISS Kit:

DO NOT EXPOSE TO TEMPERATURES ABOVE 37°C
DO NOT REFRIGERATE AFTER RECONSTITUTION

Do not use iodine or heavy metal containing preparations such as betadine for disinfection of vial stoppers. Allow alcohol-based disinfectants to evaporate before puncturing stopper.

Use separate syringes for reconstituting Sealer Protein and Thrombin solutions and for application to prevent premature clotting.

After reconstitution, the product must be used within 4 hours.

ARTISS Kit contains the following substances in four separate vials:

- Sealer Protein Concentrate (Human)
- Fibrinolysis Inhibitor Solution (Synthetic)
- Thrombin (Human)
- Calcium Chloride Solution

Freeze-dried Sealer Protein Concentrate and Thrombin are reconstituted in Fibrinolysis Inhibitor Solution and Calcium Chloride Solution, respectively. The Sealer Protein Solution and Thrombin Solution are then combined using the DUPLOJECT Preparation and Application System, or an equivalent delivery device cleared by FDA for use with ARTISS to form the Fibrin Sealant.

Prewarming ARTISS Kit with FIBRINOTHERM

If a FIBRINOTHERM device is not available, contact Baxter (1-800-423-2090) for assistance. See FIBRINOTHERM manual for complete operating instructions.

1. Plug the FIBRINOTHERM Heating and Stirring Device into an electrical socket and activate the warmer (amber switch). Ensure that the stirring mechanism of the FIBRINOTHERM device is initially switched off (green switch).
2. Place all four vials from the ARTISS Kit into the prewarmed wells of the FIBRINOTHERM, using the appropriately sized adapter rings, and allow the vials to warm for up to 5 minutes (room temperature product may take less time).

Preparation of Sealer Protein Solution with FIBRINOTHERM

1. Remove the flip-off caps from the vial containing the Sealer Protein Concentrate and the vial containing the Fibrinolysis Inhibitor Solution, disinfect the rubber stoppers of both vials with a germicidal solution and allow to dry.
2. Transfer the Fibrinolysis Inhibitor Solution into the vial containing the freeze-dried Sealer Protein Concentrate using the sterile reconstitution components provided with the DUPLOJECT Preparation and Application System, or an equivalent device cleared by FDA for use with ARTISS (see directions provided with the device system for specific reconstitution instructions). Gently swirl the vial to ensure that the freeze-dried material is completely soaked.
3. Place the vial into the largest opening of the FIBRINOTHERM device with the appropriate adaptor. Switch on the stirrer (green switch) and allow the vial contents to stir until all Sealer Protein Concentrate is dissolved.
4. Reconstitution of the freeze-dried Sealer Protein Concentrate is complete as soon as no undissolved particles are visible. Otherwise, return the vial to the FIBRINOTHERM device and agitate for a few more minutes until the solution appears homogeneous.

Notes:

- Do not use the Sealer Protein Concentrate until it has fully dissolved. If the Sealer Protein Concentrate has not dissolved within 20 minutes using the FIBRINOTHERM device, discard the vial and prepare a fresh kit.
- If not used promptly, keep the Sealer Protein Solution at 37°C without stirring. To ensure homogeneity, switch on the stirrer of the FIBRINOTHERM device shortly before drawing up the solution.

Preparation of Thrombin Solution with FIBRINOTHERM

1. Remove the flip-off caps from the vial containing Thrombin and the vial containing Calcium Chloride Solution, disinfect the rubber stoppers of both vials with a germicidal solution and allow to dry.

ARTISS [Fibrin Sealant (Human)]

- Transfer the contents of the vial with Calcium Chloride Solution into the vial containing the freeze-dried Thrombin using the sterile reconstitution components provided with the DUPLOJECT Preparation and Application System, or an equivalent device cleared by FDA for use with ARTISS (see directions provided with the device system for specific reconstitution instructions).
- Swirl briefly.
- Place the vial into the adapted opening of the FIBRINOTHERM device.
- Reconstitution of Thrombin is complete when all of the Thrombin concentrate is dissolved.
- Keep the Thrombin Solution at 37°C until used.

Transferring to the Sterile Field

For transfer of the Sealer Protein Solution and the Thrombin Solution to the sterile field, the scrub nurse should withdraw the solutions while the circulating nurse holds the non-sterile vials. The solutions should be withdrawn slowly by firm constant aspiration to reduce the risk of large air bubbles.

See *DOSAGE AND ADMINISTRATION, Method of Application (2.3)*.

2.2 Preparation of ARTISS Pre-filled Syringe (Frozen)

During preparation of ARTISS (frozen):

DO NOT EXPOSE TO TEMPERATURES ABOVE 37°C

DO NOT MICROWAVE

DO NOT REFRIGERATE OR RE-FREEZE

Do not use ARTISS (frozen) unless it is completely thawed and warmed (liquid consistency).

Do not remove the protective syringe cap until use.

After thawing, the product must be stored between 15°C and 37°C (room temperature and 37°C).

The product must be used within 12 hours after warming to 33-37°C or removal from original pouches.

ARTISS (frozen) can be prepared (thawed) using one of two options:

Room Temperature Thawing

Approximate thawing times when using this method are:

| Pack Size | Room Temperature (In Pouches) |
|-----------|----------------------------------|
| 2 mL | 60 minutes |
| 4 mL | 110 minutes |
| 10 mL | 160 minutes |

Unopened pouches, thawed at room temperature, may be stored for up to 7 days at 15-25°C.

Prior to use, the product should be warmed to 33-37°C:

| Pack Size | 33°C to 37°C Incubator (In Pouches) |
|-----------|--|
| 2 mL | 15 minutes |
| 4 mL | 25 minutes |
| 10 mL | 35 minutes |

Quick Thawing

Thawing on the sterile field using a water bath

33°C to 37°C sterile water bath - transfer plunger and the inner pouch to the sterile field, remove pre-filled syringe from inner pouch and place directly into sterile water bath. Ensure the contents of the pre-filled syringe are completely immersed under the water.

Approximate thawing times when using this method are:

| Pack Size | 33°C to 37°C Sterile Water Bath (Pouches Removed) |
|-----------|--|
| 2 mL | 5 minutes |
| 4 mL | 5 minutes |
| 10 mL | 12 minutes |

Thawing off the sterile field using a water bath

33°C to 37°C non-sterile water bath in two pouches - maintain the pre-filled syringe in both pouches and place into a water bath off the sterile field for appropriate time. Ensure the pouches remain submerged throughout thawing. Remove from the water bath after thawing, dry external pouch and transfer inner pouch with pre-filled syringe and plunger onto the sterile field.

Approximate thawing times when using this method are:

| Pack Size | 33°C to 37°C Non-Sterile Water Bath (In Pouches) |
|-----------|---|
| 2 mL | 30 minutes |
| 4 mL | 40 minutes |

ARTISS [Fibrin Sealant (Human)]

10 mL

80 minutes

Thawing off the sterile field using an incubator

33°C to 37°C incubator in pouches – maintain the pre-filled syringe in both pouches and place into an incubator for appropriate time. Remove from incubator after thawing and transfer inner pouch with pre-filled syringe and plunger onto the sterile field.

Approximate thawing times when using this method are:

| Pack Size | 33°C to 37°C Incubator (In Pouches) |
|-----------|--|
| 2 mL | 40 minutes |
| 4 mL | 85 minutes |
| 10 mL | 105 minutes |

See *DOSAGE AND ADMINISTRATION, Method of Application (2.3)*.

2.3 Method of Application

Apply ARTISS using the Easyspray and Spray Set, or an equivalent device cleared by FDA for application of ARTISS. See additional instructions for use provided with the spray set.

The wound surface should be as dry as possible before application.

Apply ARTISS as a thin layer. The aerosolized sealant should be applied to the wound in a painting motion from side to side to achieve a single thin application. The wound bed will glisten in the area to which fibrin sealant has been applied. Any areas not covered by fibrin sealant will be clearly visible. The skin graft should be attached to the wound bed immediately after ARTISS has been sprayed. The surgeon has approximately 60 seconds to manipulate and position the graft prior to polymerization. To prevent adherence, wet gloves with normal saline before product contact.

After the graft has been applied, hold in the desired position by gentle compression for at least 3 minutes to ensure ARTISS sets properly and adheres firmly to the surrounding tissue. The solidified fibrin sealant reaches its final strength in approximately 2 hours after application.

The cannulas included with the DUPLOJECT Preparation and Application System or DUO Set may be used for small wounds or for edges of a skin graft that did not adhere to the wound bed (see *WARNINGS/PRECAUTIONS Application Precautions (5.3)*). Immediately before application, expel and discard the first several drops from the application cannula to ensure adequate mixing of the Sealer Protein and Thrombin solutions.

Freeze-Dried: Refer to instructions for use provided with the DUPLOJECT Preparation and Application System.

Frozen: DUO Set Instructions (see Figure 1 below):

1. Insert plunger into syringe barrel.
2. Firmly connect the two syringe nozzles to the joining piece and secure it by fastening the tether strap to the syringe.
3. Fit an application cannula to the joining piece.

If application of ARTISS is interrupted, replace the cannula immediately before application is resumed.

Figure 1.
DUO SET A

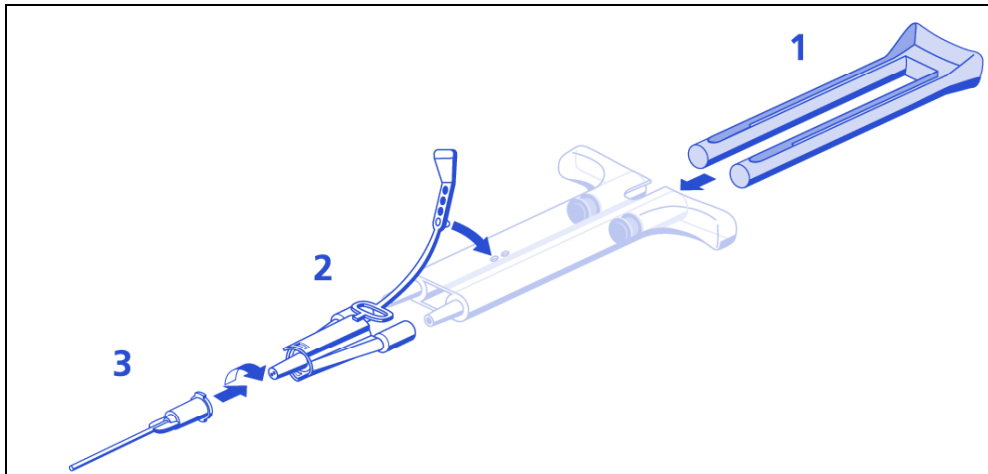

Vials and pre-filled syringes are for single use only. Discard unused contents.

3 DOSAGE FORMS AND STRENGTHS

3.1 Presentations and Pack Sizes

ARTISS Kit (Freeze-Dried) is supplied as 2 mL, 4 mL and 10 mL (total volume) pack sizes with and without the DUPLOJECT Preparation and Application System.

ARTISS Pre-filled Syringe (Frozen) is supplied as 2 mL, 4 mL and 10 mL (total volume) pack sizes with the DUO Set.

ARTISS [Fibrin Sealant (Human)]

3.2 Package Contents

ARTISS Kit (Freeze-Dried)

1. Sealer Protein Concentrate (Human), Vapor Heated, Solvent/Detergent Treated, Freeze-Dried, Sterile
2. Fibrinolysis Inhibitor Solution (Synthetic), Sterile
3. Thrombin (Human), Vapor Heated, Solvent/Detergent Treated, Freeze-Dried, Sterile
4. Calcium Chloride Solution, Sterile
5. DUPLOJECT Preparation and Application System (if indicated on the carton)

ARTISS Pre-filled Syringe (Frozen)

1. (1) Sealer Protein Solution, Vapor Heated, Solvent/Detergent Treated, Sterile
2. (2) Thrombin Solution, Vapor Heated, Solvent/Detergent Treated, Sterile
3. Sterile accessory devices (DUO Set: 1 plunger, 2 joining pieces and 4 application cannulas) are included with each pre-filled syringe

The reconstituted solution or pre-filled syringe contains:

Sealer Protein Solution

| | |
|---|--------------------|
| Total protein: | 96 – 125 mg/mL |
| Fibrinogen: | 67 – 106 mg/mL |
| Fibrinolysis Inhibitor (Synthetic): | 2250 – 3750 KIU/mL |
| Other ingredients include: human albumin, tri-sodium citrate, histidine, niacinamide, polysorbate 80 and water for injection (WFI). | |

Thrombin Solution

| | |
|--|-----------------|
| Thrombin (Human): | 2.5 – 6.5 IU/mL |
| Calcium Chloride: | 36 – 44 µmol/mL |
| Other ingredients include: human albumin, sodium chloride and water for injection (WFI). | |

4 CONTRAINDICATIONS

4.1 Intravascular Application

Do not inject ARTISS directly into blood vessels. Intravascular application of ARTISS may result in life-threatening thromboembolic events.

4.2 Aprotinin Hypersensitivity

Do not use ARTISS in individuals with a known hypersensitivity to aprotinin (see *WARNINGS/PRECAUTIONS, Hypersensitivity/Allergic/Anaphylactic Reactions (5.1) and ADVERSE REACTIONS, Overall Adverse Reactions (6.1)*).

5 WARNINGS/PRECAUTIONS

5.1 Hypersensitivity/Allergic/Anaphylactic Reactions

Hypersensitivity or allergic/anaphylactoid reactions may occur with the use of ARTISS. Cases (<1/10,000) have been reported in post marketing experience with Baxter's fibrin sealant (see *ADVERSE REACTIONS, Post Marketing (6.3)*). In specific cases, these reactions have progressed to severe anaphylaxis. Such reactions may especially be seen if ARTISS is applied repeatedly over time or in the same setting, or if systemic aprotinin has been administered previously. Even if the first treatment was well tolerated, a subsequent administration of ARTISS or systemic aprotinin may not exclude the occurrence of an allergic reaction. Such reactions may also occur in patients receiving ARTISS for the first time.

Discontinue administration of ARTISS in the event of hypersensitivity reactions. Remove the already applied, polymerized product from the surgical field. Mild reactions can be managed with antihistamines. Severe hypotensive reactions require immediate intervention using current principles of shock therapy.

5.2 Infection Risk from Human Plasma

ARTISS is made from human plasma. Products made from human plasma may contain infectious agents, such as viruses, that can cause disease. The risk that such products will transmit an infectious agent has been reduced by screening plasma donors for prior exposure to certain viruses, by testing for the presence of certain current virus infections, and by inactivating and removing certain viruses (see *CLINICAL PHARMACOLOGY, Other Clinical Pharmacology Information (12.4)*). Despite these measures, such products can still potentially transmit disease. Because this product is made from human blood, it may carry a risk of transmitting infectious agents, e.g., viruses, and theoretically, the Creutzfeldt-Jakob disease (CJD) agent. All infections thought by a physician possibly to have been transmitted by this product should be reported by the physician or other healthcare provider to Baxter Healthcare Corporation, telephone # 1-866-888-2472.

5.3 Application Precautions

Apply ARTISS as a thin layer. Excessive clot thickness may negatively interfere with the product's efficacy and the wound healing process.

Caution must be used when applying fibrin sealant using pressurized gas. Any application of pressurized gas may be associated with a potential risk of air embolism, tissue rupture or gas entrapment with compression which may be life threatening.

The sealer protein and thrombin solutions can be denatured by alcohol, iodine or heavy metal ions. If any of these substances have been used to clean the wound area, the area must be thoroughly rinsed before application of ARTISS and made as dry as possible.

6 ADVERSE REACTIONS

6.1 Overall Adverse Reactions

Adverse reactions occurring in greater than 1% of patients treated with ARTISS were skin graft failure and pruritus.

Hypersensitivity/Allergic/Anaphylactic Reactions: Hypersensitivity or allergic/anaphylactoid reactions may occur (see *WARNINGS/PRECAUTIONS, Hypersensitivity/Allergic/Anaphylactic Reactions (5.1)*). No adverse events of this type were reported during clinical trials.

ARTISS [Fibrin Sealant (Human)]

6.2 Clinical Trials Experience

Because clinical trials are conducted under widely varying conditions, adverse reaction rates observed in the clinical trials of a drug cannot be directly compared to rates in the clinical trials of another drug and may not reflect the rates observed in practice.

The following adverse reactions have been reported from a clinical trial where ARTISS was used to affix split thickness sheet skin grafts to excised burn wounds (see *CLINICAL STUDIES (14)*). A total of 8 non-serious adverse reactions were deemed related to the use of ARTISS by the investigator. Of the 8 related non-serious adverse reactions, 5 were incidences of skin graft failure: 4 were graft detachment/non-adherence and 1 was graft necrosis. The graft detachment in 2 patients may have been related to the maximum thawing temperature (40°C) being exceeded during study product preparation. The 3 other non-serious adverse reactions considered related to ARTISS were 2 incidences of pruritus and 1 incidence of dermal cyst. The graft necrosis and the 2 cases of pruritus considered related to ARTISS each had an equivalent adverse reaction with the exact start date and severity reported at a control wound where skin grafts were affixed with staples. Therefore, these events are most likely not related to ARTISS, but instead are expected outcomes for any grafted wound regardless of the method of attachment.

Overall, the data collected and analyzed during this study demonstrated that ARTISS is safe for the attachment of sheet skin grafts in subjects with deep partial thickness or full thickness burn wounds.

The adverse reactions and their frequencies are summarized in Table 2:

Table 2.

| Adverse reactions (Preferred Term) | Number of events/ Number of patients treated |
|------------------------------------|---|
| Dermal cyst | 1/138 |
| Pruritus | 2/138 |
| Skin graft failure | 5/138 |

6.3 Post Marketing

The following adverse reactions reflect what has been reported in post marketing experience with Baxter's fibrin sealant that could reasonably be expected to occur with ARTISS:

Immune system disorders: anaphylactic responses, hypersensitivity

Cardiac disorders: bradycardia, tachycardia

Respiratory, thoracic and mediastinal disorders: dyspnea

Gastrointestinal disorders: nausea

Skin and subcutaneous tissue disorders: urticaria

General disorders and administration site conditions: flushing, impaired healing, edema, pyrexia

Injury, poisoning and procedural complication: seroma

Because these reactions are reported voluntarily from a population of uncertain size, it is not always possible to reliably estimate the frequency or establish a causal relationship to drug exposure.

7 DRUG INTERACTIONS

No interaction studies have been performed.

8 USE IN SPECIFIC POPULATIONS

8.1 Pregnancy

Pregnancy Category C

Animal reproduction studies have not been conducted with ARTISS. It is also not known whether ARTISS can cause fetal harm when administered to a pregnant woman or can affect reproduction capacity. Some viruses, such as parvovirus B19, are particularly difficult to remove or inactivate at this time. Parvovirus B19 most seriously affects pregnant women (fetal infection). ARTISS should be given to a pregnant woman only if deemed medically necessary.

8.3 Lactating Women

It is not known whether this drug is excreted in human milk. Because many drugs are excreted in human milk, caution should be exercised when ARTISS is administered to a lactating woman.

8.4 Pediatric Use

In a clinical trial ARTISS, the efficacy and safety of ARTISS in pediatric patients (1 to 16 years of age) was not different from an adult population.

8.5 Geriatric Use

Clinical studies of ARTISS did not include any subjects aged 65 and over.

11 DESCRIPTION

ARTISS [Fibrin Sealant], Vapor Heated, Solvent Detergent Treated, (ARTISS) is a two-component fibrin sealant made from pooled human plasma. When combined, the two components, Sealer Protein (Human) and Thrombin (Human), mimic the final stage of the blood coagulation cascade.

Sealer Protein (Human)

Sealer Protein (Human) is a sterile, non-pyrogenic, vapor-heated and solvent/detergent treated preparation made from pooled human plasma. Sealer Protein (Human) is provided either as a freeze-dried powder [Sealer Protein Concentrate (Human)] for reconstitution with Fibrinolysis Inhibitor Solution (Synthetic) or as a frozen liquid solution pre-filled into one side of a dual-chambered syringe (1). The active ingredient in Sealer Protein (Human) is

ARTISS [Fibrin Sealant (Human)]

fibrinogen. A Fibrinolysis Inhibitor, Aprotinin (Synthetic) is included in the Sealer Protein (Human) component to delay fibrinolysis. Aprotinin (Synthetic) is manufactured by solid phase synthesis from materials completely of non-human/non-animal origin.

To obtain Sealer Protein (Human), cryoprecipitate derived from the plasma is washed, dissolved in buffer solution, solvent/detergent treated, vapor heat treated, sterile filtered and either freeze-dried in vials or frozen in pre-filled syringes.

Thrombin (Human)

Thrombin (Human) is a sterile, non-pyrogenic, vapor-heated and solvent/detergent treated preparation made from pooled human plasma. Thrombin (Human) is also provided either as a freeze-dried powder for reconstitution with Calcium Chloride Solution or as a frozen liquid solution pre-filled into one side of a dual-chambered syringe (2).

Thrombin is prepared from plasma through a series of separation and filtration steps followed by incubation of the solution with calcium chloride to activate prothrombin to thrombin. The solution subsequently undergoes ultra/diafiltration, vapor heat treatment, solvent/detergent treatment, sterile filtration and either freeze-drying in vials or frozen in pre-filled syringes.

Sealer Protein (Human) and Thrombin (Human) are made from pooled human plasma collected at US licensed collection centers. The vapor heat and solvent/detergent treatment steps used in the manufacturing process have been shown to be capable of significant viral reduction. No procedure, however, has been shown to be completely effective in removing viral infectivity from derivatives of human plasma (see *CLINICAL PHARMACOLOGY, Other Clinical Pharmacology Information (12.4) and WARNINGS/PRECAUTIONS, Infection Risk from Human Plasma (5.2)*).

See *DOSAGE FORMS AND STRENGTHS (3)*.

12 CLINICAL PHARMACOLOGY

12.1 Mechanism of Action

Upon mixing Sealer Protein (Human) and Thrombin (Human), soluble fibrinogen is transformed into fibrin that adheres to the wound surface and to the skin graft to be affixed. Due to the low thrombin concentration, polymerization of ARTISS will take approximately 60 seconds.

12.2 Pharmacodynamics

Thrombin is a highly specific protease that transforms the fibrinogen contained in Sealer Protein (Human) into fibrin (see *Pharmacokinetics (12.3)*). Fibrinolysis Inhibitor, Aprotinin (Synthetic), is a polyvalent protease inhibitor that prevents premature degradation of fibrin. Free Aprotinin and its metabolites have a half-life of 30 to 60 minutes and are eliminated by the kidney. Preclinical studies with different fibrin sealant preparations simulating the fibrinolytic activity generated by extracorporeal circulation in patients during cardiovascular surgery have shown that incorporation of aprotinin in the product formulation increases resistance of the fibrin sealant clot to degradation in a fibrinolytic environment.

12.3 Pharmacokinetics

Pharmacokinetic studies were not conducted. Because ARTISS is applied only topically, systemic exposure or distribution to other organs or tissues is not expected.

12.4 Other Clinical Pharmacology Information

Viral Clearance

The manufacturing procedure for ARTISS includes processing steps designed to further reduce the risk of viral transmission. In particular, vapor heating and solvent/detergent treatment processes are included in the manufacturing of Sealer Protein Concentrate and Thrombin. Validation studies were conducted using samples drawn from manufacturing intermediates for each of the two human plasma derived components. These samples were spiked with stock virus suspensions of known titers followed by further processing under conditions equivalent to those in the respective manufacturing steps. The virus reduction factors (expressed as \log_{10}) of independent manufacturing steps are shown in Table 3 for each of the viruses tested:

Table 3.

| Reduction Factors for Virus Removal and/or Inactivation Sealer Protein Component | | | | | |
|---|--|------|-------|-------|------|
| Manufacturing Step | Mean Reduction Factors [\log_{10}] of Virus Tested | | | | |
| | HIV-1 | HAV | BVDV | PRV | MMV |
| Solvent/Detergent Treatment | >5.3 | n.d. | >5.7 | >5.9 | n.d. |
| Vapor Heat Treatment | >5.5 | >5.6 | >5.7 | >6.7 | 1.2 |
| Overall Reduction Factor (ORF) | >10.8 | >5.6 | >11.4 | >12.6 | 1.2 |
| Reduction Factors for Virus Removal and/or Inactivation Thrombin Component | | | | | |
| Manufacturing Step | Mean Reduction Factors [\log_{10}] of Virus Tested | | | | |
| | HIV-1 | HAV | BVDV | PRV | MMV |
| Thrombin precursor mass capture | n.d. | n.d. | 1.8 | n.d. | n.d. |
| Vapor Heat Treatment | >5.5 | >4.9 | >5.3 | >6.7 | 1.0 |
| Solvent/Detergent Treatment | >5.3 | n.d. | >5.5 | >6.4 | n.d. |
| Ion Exchange Chromatography | n.d. | n.d. | n.d. | n.d. | 3.6 |
| Overall Reduction Factor (ORF) | >10.8 | >4.9 | >12.6 | >13.1 | 4.6 |

n.d. = not determined

HIV-1: Human immunodeficiency virus 1; **HAV:** Hepatitis A virus; **BVDV:** Bovine viral diarrhea virus, a model for Hepatitis C virus; **PRV:** Pseudorabies virus, a model for enveloped DNA viruses, among those Hepatitis B virus; **MMV:** Mice minute virus, a model for Human Parvovirus B19.

ARTISS [Fibrin Sealant (Human)]

In addition, Human Parvovirus B19 (B19V) was used to investigate the upstream Thrombin precursor mass capture step and the Thrombin and Sealer Protein vapor heating steps. Log reduction factors obtained were 1.7 for the Thrombin precursor mass capture step and 1.0 / >4 for the Sealer Protein / Thrombin vapor heating steps, respectively.

13 NONCLINICAL TOXICOLOGY

13.1 Carcinogenesis, Mutagenesis and Impairment of Fertility

Long-term animal studies to evaluate the carcinogenic potential of ARTISS or studies to determine the effect of ARTISS on fertility have not been performed.

14 CLINICAL STUDIES

ARTISS was investigated for adherence of split thickness sheet skin grafts in burn patients in a prospective, randomized, controlled, evaluator-blinded, multicenter clinical study. In each of the 138 patients, two comparable test sites were identified after burn wound excision. Skin grafts were adhered at one test site using ARTISS, and at the other test site using staples (control). The study product was applied once to the wound bed of the allocated test site during skin grafting surgery.

Of the 138 treated subjects, 94 (68.1%) were male and 44 (31.9%) were female. The mean \pm SD age was 30.8 \pm 17.6 years; 19 (13.8%) subjects were \leq 6 years old, 21 (15.2%) subjects were 7 to 18 years old, and 98 (71.0%) were > 18 years old. The mean \pm SD estimated total body surface area (TBSA) for all burn wounds was 13.6 \pm 9.2%. The mean \pm SD estimated TBSA requiring skin grafting was 8.0 \pm 6.9%. The mean \pm SD estimated TBSA for ARTISS test sites was 1.7 \pm 0.8% and for the stapled test sites was 1.7 \pm 0.7%. Burn wound thickness was classified as full thickness in 106 (76.8%) of the 138 treated subjects, and partial thickness in 32 (23.2%) subjects. The mean \pm SD volume applied was 2.7 \pm 1.9 mL (range: 0.2 to 12.0 mL). The mean \pm SD surface area treated was 166.4 \pm 95.0 cm² (range: 26.1 to 602. cm²). The mean \pm SD calculated dosing volume was 1.8 \pm 1.1 mL/100 cm² (range: 0.2 to 6.0 mL/100 cm²).

The safety population contained all 138 treated subjects; however, 11 subjects did not have an available primary endpoint assessment, leaving a modified intent-to-treat (ITT) set of 127 patients. Complete wound closure by Day 28 was achieved in 43.3% of the ARTISS test sites and 37.0% of the stapled test sites in the 127 ITT patients. The lower limit of the 97.5% confidence interval of the difference between ARTISS and staples was -0.029. A similar result was obtained in the per protocol (PP) population: complete wound closure by Day 28 was achieved in 45.3% of the ARTISS test sites and 39.6% of the stapled test sites in the 106 PP patients. The lower limit of the 97.5% confidence interval of the difference between ARTISS and staples was -0.041. Therefore, ARTISS was found to be non-inferior to staples in the ITT and PP populations at the 97.5% one-sided level for complete wound closure by Day 28 because the lower limit of the confidence interval of the difference between ARTISS and staples success rates was greater than the predefined limit of -0.1.

16 HOW SUPPLIED/STORAGE AND HANDLING

ARTISS is supplied in the following pack sizes and presentations:

Table 4.

| Pack Size | NDC Number | | |
|-----------|---------------------------|---|---|
| | ARTISS Kit (Freeze-Dried) | ARTISS Kit (Freeze-Dried) with DUPLOJECT System | ARTISS Pre-Filled Syringe (Frozen) with DUO Set |
| 2 mL | 0944-4351-03 | 0944-4351-04 | 0944-8503-02 |
| 4 mL | 0944-4351-07 | 0944-4351-08 | 0944-8503-04 |
| 10 mL | 0944-4351-11 | 0944-4351-12 | 0944-8503-10 |

See *DOSAGE FORMS AND STRENGTHS, Package Contents (3.2)*.

Storage

ARTISS Kit (Freeze-Dried)

Store at 2°C to 25°C. Avoid freezing. After reconstitution, the product must be used within 4 hours.

ARTISS Pre-filled Syringe (Frozen)

Long term: Store at \leq -20°C.

Short term: Unopened pouches, thawed at room temperature, may be stored for up to 7 days at room temperature (15-25°C) after removal from the freezer. The product must be used within 12 hours after warming to 33-37°C or removal from original pouches. **Do not refrigerate, microwave or re-freeze.**

Do not use after the expiration date. Discard if packaging of any components is damaged.

17 PATIENT COUNSELING INFORMATION

Because this product is made from human plasma, the physician should discuss the risks and benefits with the patient.

Patients should be instructed to consult their physician if symptoms of B19 virus infection appear (fever, drowsiness, chills and runny nose followed about two weeks later by a rash and joint pain (*see USE IN SPECIFIC POPULATIONS, Pregnancy (8.1)*).

Baxter Healthcare Corporation

Westlake Village, CA 91362 USA
US License No. 140

This product, or its use, may be covered by one or more US Patents including US Patent Nos. 4,640,834, 5,962,405 and 5,714,370, 6,579,537 in addition to others including patents pending.

ARTISS [Fibrin Sealant (Human)]

BAXTER, EASYSpray, FIBRINOTHERM and DUPLOJECT are trademarks of Baxter International Inc., registered in the US Patent and Trademark Office.

ARTISS is a trademark of Baxter International Inc.

Issue Date: 03/2008